

# EUREKA MATH

A STORY OF UNITS



Mathematics Curriculum



## Grade 5 • MODULE 5

Addition and Multiplication with Volume and Area

# Homework

---

---

Video tutorials: <http://embarc.online>

Version 3



## Table of Contents

**GRADE 5 • MODULE 5**

## Addition and Multiplication with Volume and Area

<b>Module Overview</b> .....	2
Topic A: Concepts of Volume .....	11
Topic B: Volume and the Operations of Multiplication and Addition .....	52
<b>Mid Module Assessment and Rubric</b> .....	128
Topic C: Area of Rectangular Figures with Fractional Side Lengths .....	138
Topic D: Drawing, Analysis, and Classification of Two-Dimensional Shapes .....	219
<b>End-of-Module Assessment and Rubric</b> .....	311
<b>Answer Key</b> .....	321

**NOTE:** Student sheets should be printed at 100% scale to preserve the intended size of figures for accurate measurements. Adjust copier or printer settings to *actual size* and set page scaling to *none*.

Name \_\_\_\_\_

Date \_\_\_\_\_

1. The following solids are made up of 1 cm cubes. Find the total volume of each figure, and write it in the chart below.

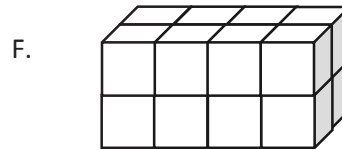
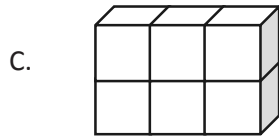
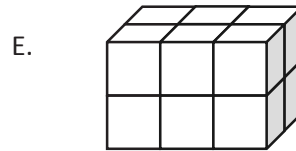
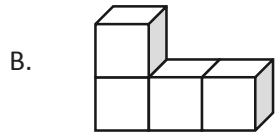
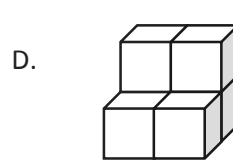
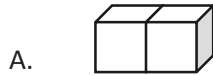
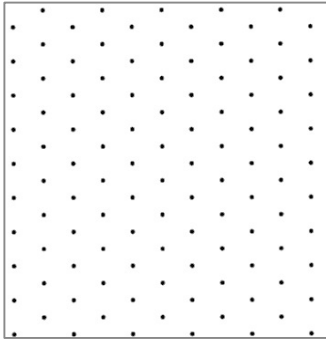

Figure	Volume	Explanation
A		
B		
C		
D		
E		
F		

2. Draw a figure with the given volume on the dot paper.

a. 3 cubic units



b. 6 cubic units

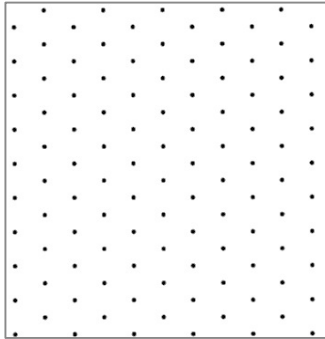

c. 12 cubic units

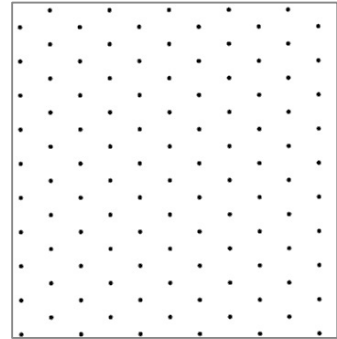

3. John built and drew a structure that has a volume of 5 cubic centimeters. His little brother tells him he made a mistake because he only drew 4 cubes. Help John explain to his brother why his drawing is accurate.

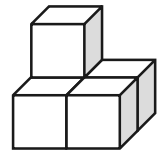

4. Draw another figure below that represents a structure with a volume of 5 cubic centimeters.

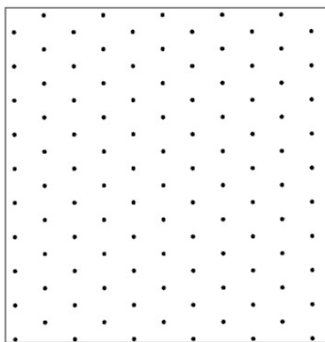

Name \_\_\_\_\_

Date \_\_\_\_\_

1. Make the following boxes on centimeter grid paper. Cut and fold each to make 3 open boxes, taping them so they hold their shapes. How many cubes would fill each box? Explain how you found the number.

a.

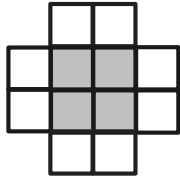

Number of cubes: \_\_\_\_\_

b.

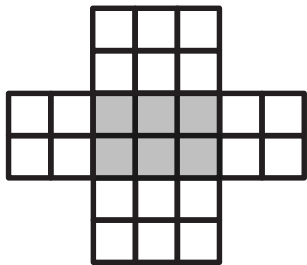

Number of cubes: \_\_\_\_\_

c.

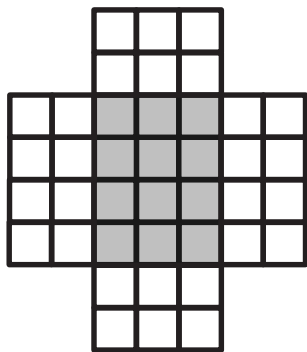

Number of cubes: \_\_\_\_\_

2. How many centimeter cubes would fit inside each box? Explain your answer using words and diagrams on each box. (The figures are not drawn to scale.)

a.



Number of cubes: \_\_\_\_\_

Explanation:

b.

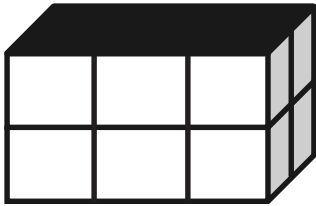

Number of cubes: \_\_\_\_\_

Explanation:

c.

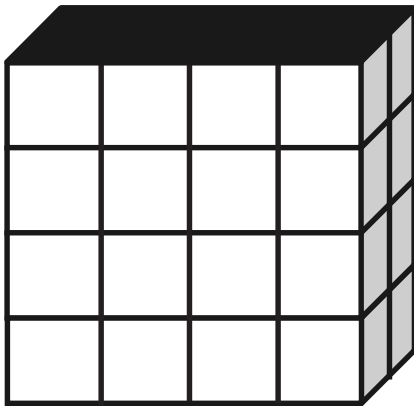

Number of cubes: \_\_\_\_\_

Explanation:

3. The box pattern below holds 24 1-centimeter cubes. Draw two different box patterns that would hold the same number of cubes.

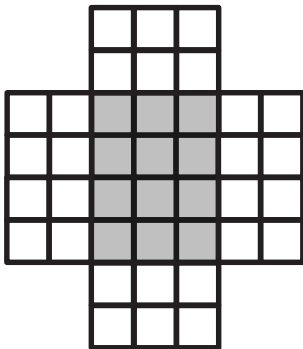

Name \_\_\_\_\_

Date \_\_\_\_\_

1. Use the prisms to find the volume.

- The rectangular prisms pictured below were constructed with 1 cm cubes.
- Decompose each prism into layers in three different ways, and show your thinking on the blank prisms.
- Complete each table.

a.

Number of Layers	Number of Cubes in Each Layer	Volume of the Prism
		cubic cm
		cubic cm
		cubic cm

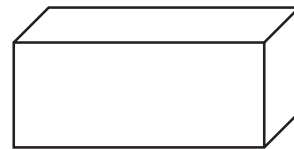
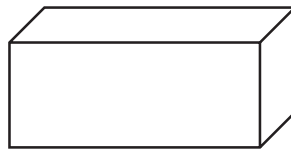
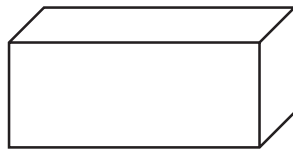
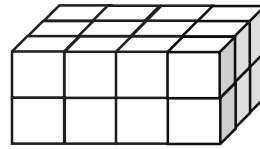

b.

Number of Layers	Number of Cubes in Each Layer	Volume of the Prism
		cubic cm
		cubic cm
		cubic cm

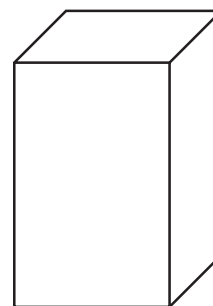
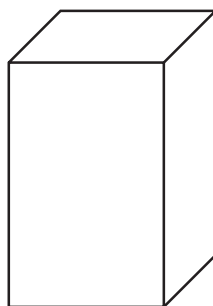
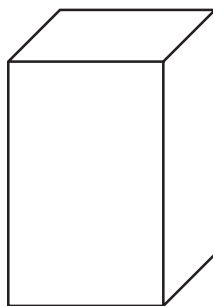
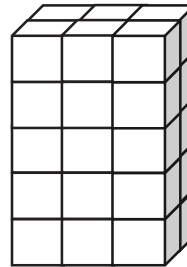

2. Stephen and Chelsea want to increase the volume of this prism by 72 cubic centimeters. Chelsea wants to add eight layers, and Stephen says they only need to add four layers. Their teacher tells them they are both correct. Explain how this is possible.

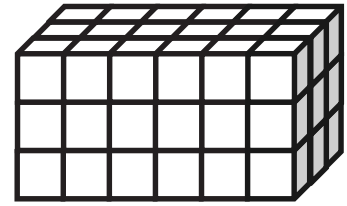

3. Juliana makes a prism 4 inches across and 4 inches wide but only 1 inch tall. She then decides to create layers equal to her first one. Fill in the chart below, and explain how you know the volume of each new prism.

Number of Layers	Volume	Explanation
3		
5		
7		

4. Imagine the rectangular prism below is 4 meters long, 3 meters tall, and 2 meters wide. Draw horizontal lines to show how the prism could be decomposed into layers that are 1 meter in height.

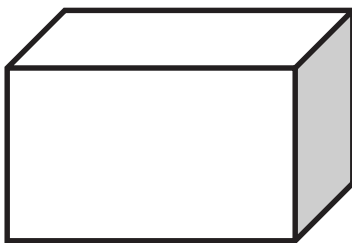

It has \_\_\_\_\_ layers from top to bottom.

Each horizontal layer contains \_\_\_\_\_ cubic meters.

The volume of this prism is \_\_\_\_\_



Name \_\_\_\_\_

Date \_\_\_\_\_

1. Each rectangular prism is built from centimeter cubes. State the dimensions, and find the volume.

a.

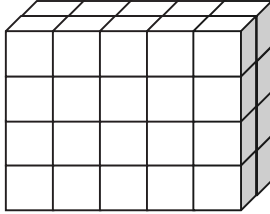

Length: \_\_\_\_\_ cm

Width: \_\_\_\_\_ cm

Height: \_\_\_\_\_ cm

Volume: \_\_\_\_\_  $\text{cm}^3$ 

b.

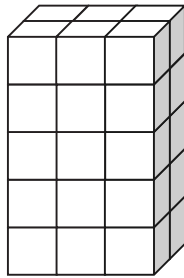

Length: \_\_\_\_\_ cm

Width: \_\_\_\_\_ cm

Height: \_\_\_\_\_ cm

Volume: \_\_\_\_\_  $\text{cm}^3$ 

c.

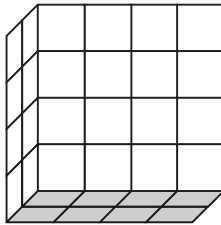

Length: \_\_\_\_\_ cm

Width: \_\_\_\_\_ cm

Height: \_\_\_\_\_ cm

Volume: \_\_\_\_\_  $\text{cm}^3$ 

d.

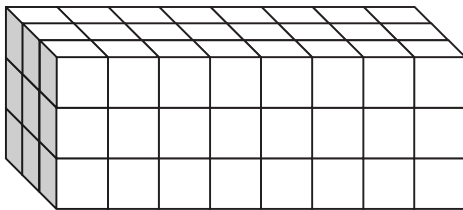

Length: \_\_\_\_\_ cm

Width: \_\_\_\_\_ cm

Height: \_\_\_\_\_ cm

Volume: \_\_\_\_\_  $\text{cm}^3$ 

2. Write a multiplication sentence that you could use to calculate the volume for each rectangular prism in Problem 1. Include the units in your sentences.

a. \_\_\_\_\_

b. \_\_\_\_\_

c. \_\_\_\_\_

d. \_\_\_\_\_

3. Calculate the volume of each rectangular prism. Include the units in your number sentences.

a.

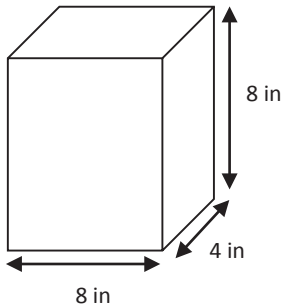

Volume: \_\_\_\_\_

b.

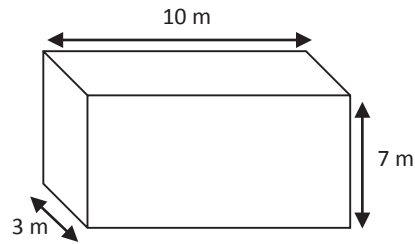

Volume: \_\_\_\_\_

4. Mrs. Johnson is constructing a box in the shape of a rectangular prism to store clothes for the summer. It has a length of 28 inches, a width of 24 inches, and a height of 30 inches. What is the volume of the box?

5. Calculate the volume of each rectangular prism using the information that is provided.

a. Face area: 56 square meters

Height: 4 meters

b. Face area: 169 square inches

Height: 14 inches

Name \_\_\_\_\_

Date \_\_\_\_\_

1. Johnny filled a container with 30 centimeter cubes. Shade the beaker to show how much water the container will hold. Explain how you know.

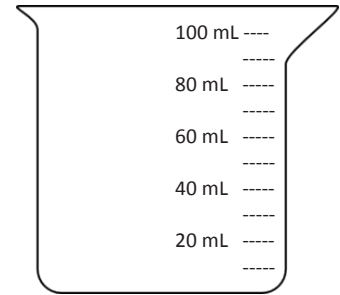

2. A beaker contains 250 mL of water. Jack wants to pour the water into a container that will hold the water. Which of the containers pictured below could he use? Explain your choices.

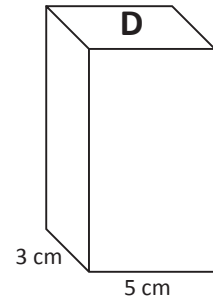
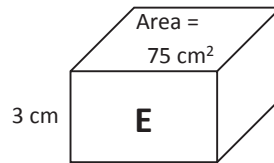
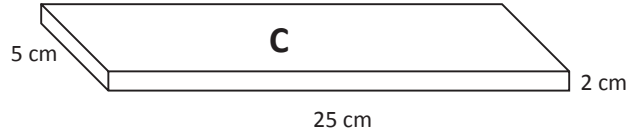
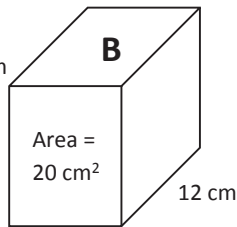
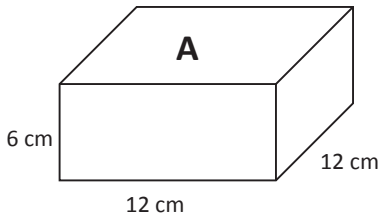

3. On the back of this paper, describe the details of the activities you did in class today. Include what you learned about cubic centimeters and milliliters. Give an example of a problem you solved with an illustration.

Name \_\_\_\_\_

Date \_\_\_\_\_

1. Find the total volume of the figures, and record your solution strategy.

a.

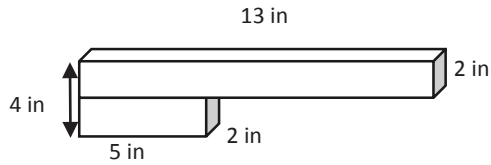

Volume: \_\_\_\_\_

Solution Strategy:

b.

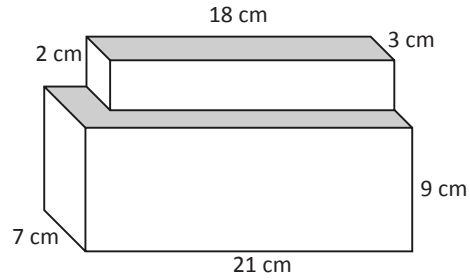

Volume: \_\_\_\_\_

Solution Strategy:

c.

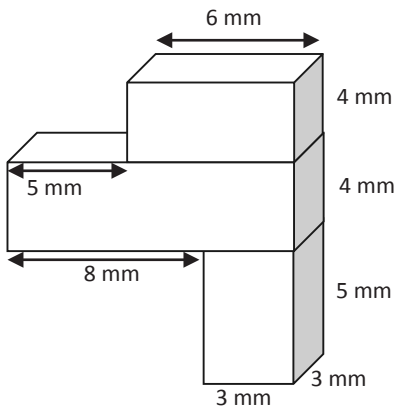

Volume: \_\_\_\_\_

Solution Strategy:

d.

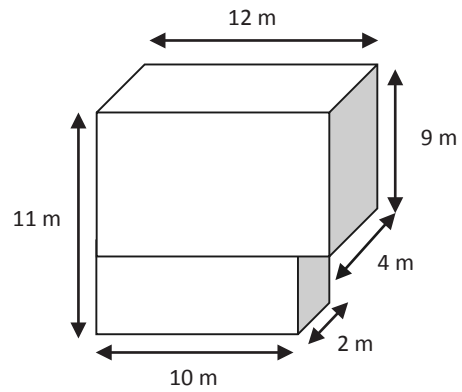

Volume: \_\_\_\_\_

Solution Strategy:

2. The figure below is made of two sizes of rectangular prisms. One type of prism measures 3 inches by 6 inches by 14 inches. The other type measures 15 inches by 5 inches by 10 inches. What is the total volume of this figure?

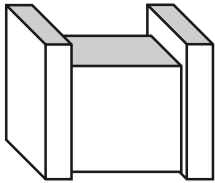

3. The combined volume of two identical cubes is 250 cubic centimeters. What is the measure of one cube's edge?

4. A fish tank has a base area of  $45 \text{ cm}^2$  and is filled with water to a depth of 12 cm. If the height of the tank is 25 cm, how much more water will be needed to fill the tank to the brim?

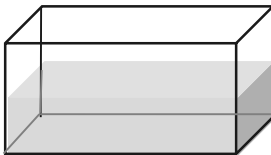

5. Three rectangular prisms have a combined volume of 518 cubic feet. Prism A has one-third the volume of Prism B, and Prisms B and C have equal volume. What is the volume of each prism?

Name \_\_\_\_\_

Date \_\_\_\_\_

Wren makes some rectangular display boxes.

1. Wren's first display box is 6 inches long, 9 inches wide, and 4 inches high. What is the volume of the display box? Explain your work using a diagram.
  
  
  
  
  
  
  
  
  
  
2. Wren wants to put some artwork into three shadow boxes. She knows they all need a volume of 60 cubic inches, but she wants them all to be different. Show three different ways Wren can make these boxes by drawing diagrams and labeling the measurements.

Shadow Box A	Shadow Box B
Shadow Box C	

3. Wren wants to build a box to organize her scrapbook supplies. She has a stencil set that is 12 inches wide that needs to lay flat in the bottom of the box. The supply box must also be no taller than 2 inches. Name one way she could build a supply box with a volume of 72 cubic inches.
4. After all of this organizing, Wren decides she also needs more storage for her soccer equipment. Her current storage box measures 1 foot long by 2 feet wide by 2 feet high. She realizes she needs to replace it with a box with 12 cubic feet of storage, so she doubles the width.
- Will she achieve her goal if she does this? Why or why not?
  - If she wants to keep the height the same, what could the other dimensions be for a 12-cubic-foot storage box?
  - If she uses the dimensions in part (b), what is the area of the new storage box's floor?
  - How has the area of the bottom in her new storage box changed? Explain how you know.

Name \_\_\_\_\_

Date \_\_\_\_\_

1. I have a prism with the dimensions of 6 cm by 12 cm by 15 cm. Calculate the volume of the prism, and then give the dimensions of three different prisms that each have  $\frac{1}{3}$  of the volume.

	Length	Width	Height	Volume
Original Prism	6 cm	12 cm	15 cm	
Prism 1				
Prism 2				
Prism 3				

2. Sunni's bedroom has the dimensions of 11 ft by 10 ft by 10 ft. Her den has the same height but double the volume. Give two sets of the possible dimensions of the den and the volume of the den.



Name \_\_\_\_\_

Date \_\_\_\_\_

1. Find three rectangular prisms around your house. Describe the item you are measuring (cereal box, tissue box, etc.), and then measure each dimension to the nearest whole inch, and calculate the volume.

## a. Rectangular Prism A

Item:

Height: \_\_\_\_\_ inches

Length: \_\_\_\_\_ inches

Width: \_\_\_\_\_ inches

Volume: \_\_\_\_\_ cubic inches

## b. Rectangular Prism B

Item:

Height: \_\_\_\_\_ inches

Length: \_\_\_\_\_ inches

Width: \_\_\_\_\_ inches

Volume: \_\_\_\_\_ cubic inches

## c. Rectangular Prism C

Item:

Height: \_\_\_\_\_ inches

Length: \_\_\_\_\_ inches

Width: \_\_\_\_\_ inches

Volume: \_\_\_\_\_ cubic inches

Name \_\_\_\_\_

Date \_\_\_\_\_

1. John tiled some rectangles using square units. Sketch the rectangles if necessary. Fill in the missing information, and then confirm the area by multiplying.

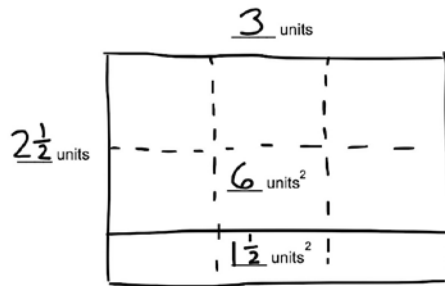
a. **Rectangle A:**

Rectangle A is

3 units long  $2\frac{1}{2}$  units wide

Area = \_\_\_\_\_ units<sup>2</sup>

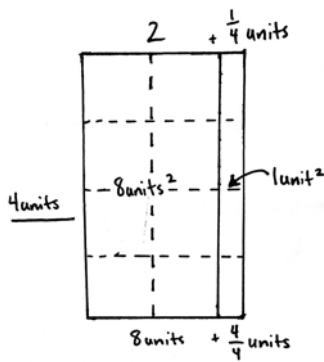
b. **Rectangle B:**

Rectangle B is

\_\_\_\_\_ units long \_\_\_\_\_ units wide

Area = \_\_\_\_\_ units<sup>2</sup>

c. **Rectangle C:**

Rectangle C is

$\frac{3}{4}$  units long 4 units wide

Area = \_\_\_\_\_ units<sup>2</sup>

d. **Rectangle D:**

Rectangle D is

2 units long  $1\frac{3}{4}$  units wide

Area = \_\_\_\_\_ units<sup>2</sup>

2. Rachel made a mosaic from different color rectangular tiles. Three tiles measured  $3\frac{1}{2}$  inches  $\times$  3 inches. Six tiles measured 4 inches  $\times$   $3\frac{1}{4}$  inches. What is the area of the whole mosaic in square inches?

3. A garden box has a perimeter of  $27\frac{1}{2}$  feet. If the length is 9 feet, what is the area of the garden box?

Name \_\_\_\_\_

Date \_\_\_\_\_

1. Kristen tiled the following rectangles using square units. Sketch the rectangles, and find the areas. Then, confirm the area by multiplying. Rectangle A has been sketched for you.

## a. Rectangle A:

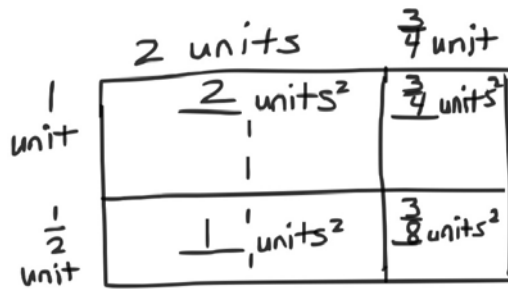

Rectangle A is

\_\_\_\_\_ units long  $\times$  \_\_\_\_\_ units wideArea = \_\_\_\_\_ units<sup>2</sup>

## b. Rectangle B:

Rectangle B is

 $2\frac{1}{2}$  units long  $\times$   $\frac{3}{4}$  unit wideArea = \_\_\_\_\_ units<sup>2</sup>

## c. Rectangle C:

Rectangle C is

 $3\frac{1}{3}$  units long  $\times$   $2\frac{1}{2}$  units wideArea = \_\_\_\_\_ units<sup>2</sup>

d. **Rectangle D:**

Rectangle D is

$$3\frac{1}{2} \text{ units long} \times 2\frac{1}{4} \text{ units wide}$$

$$\text{Area} = \underline{\hspace{2cm}} \text{ units}^2$$

2. A square has a perimeter of 25 inches. What is the area of the square?

Name \_\_\_\_\_

Date \_\_\_\_\_

1. Measure each rectangle to the nearest  $\frac{1}{4}$  inch with your ruler, and label the dimensions. Use the area model to find the area.

a.

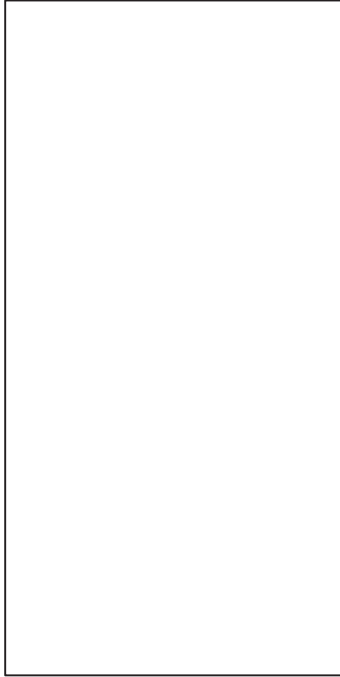

b.



c.

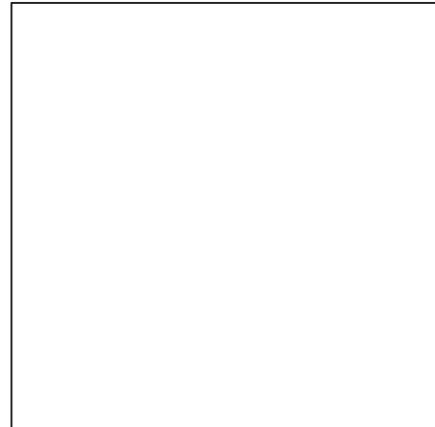

d.



e.



2. Find the area of rectangles with the following dimensions. Explain your thinking using the area model.

a.  $2\frac{1}{4}\text{ yd} \times \frac{1}{4}\text{ yd}$

b.  $2\frac{1}{2}\text{ ft} \times 1\frac{1}{4}\text{ ft}$

3. Kelly buys a tarp to cover the area under her tent. The tent is 4 feet wide and has an area of 31 square feet. The tarp she bought is  $5\frac{1}{3}$  feet by  $5\frac{3}{4}$  feet. Can the tarp cover the area under Kelly's tent? Draw a model to show your thinking.

4. Shannon and Leslie want to carpet a  $16\frac{1}{2}$ -ft by  $16\frac{1}{2}$ -ft square room. They cannot put carpet under an entertainment system that juts out. (See the drawing below.)

- a. In square feet, what is the area of the space with no carpet?

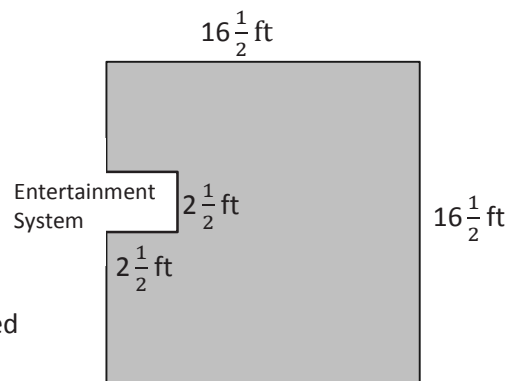

- b. How many square feet of carpet will Shannon and Leslie need to buy?

Name \_\_\_\_\_

Date \_\_\_\_\_

1. Find the area of the following rectangles. Draw an area model if it helps you.

a.  $\frac{8}{3} \text{ cm} \times \frac{24}{4} \text{ cm}$

b.  $\frac{32}{5} \text{ ft} \times 3\frac{3}{8} \text{ ft}$

c.  $5\frac{4}{6} \text{ in} \times 4\frac{3}{5} \text{ in}$

d.  $\frac{5}{7} \text{ m} \times 6\frac{3}{5} \text{ m}$

2. Chris is making a tabletop from some leftover tiles. He has 9 tiles that measure  $3\frac{1}{8}$  inches long and  $2\frac{3}{4}$  inches wide. What is the greatest area he can cover with these tiles?



3. A hotel is recarpeting a section of the lobby. Carpet covers the part of the floor as shown below in gray. How many square feet of carpeting will be needed?

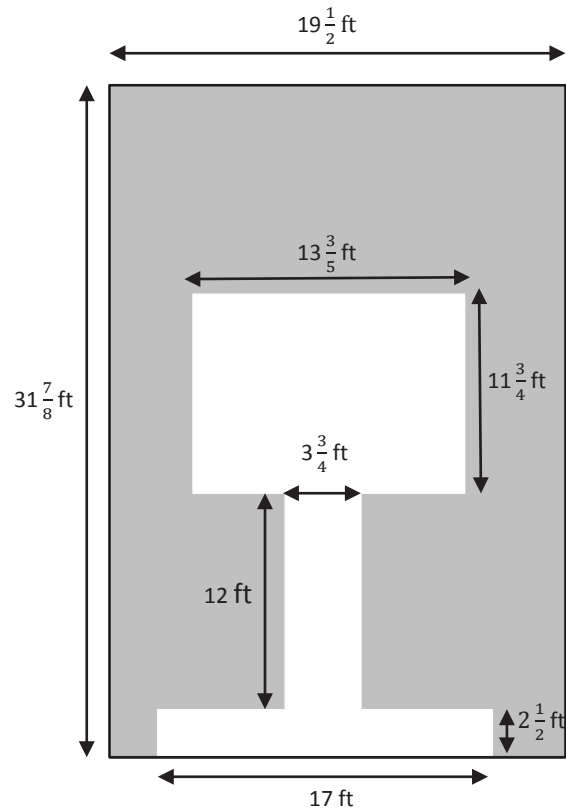



3. A-Plus Glass is making windows for a new house that is being built. The box shows the list of sizes they must make.

**15 windows**  $4\frac{3}{4}$ -ft long and  $3\frac{3}{5}$ -ft wide

**7 windows**  $2\frac{4}{5}$ -ft wide and  $6\frac{1}{2}$ -ft long

How many square feet of glass will they need?

4. Mr. Johnson needs to buy seed for his backyard lawn.
- If the lawn measures  $40\frac{4}{5}$  ft by  $50\frac{7}{8}$  ft, how many square feet of seed will he need to cover the entire area?
  - One bag of seed will cover 500 square feet if he sets his seed spreader to its highest setting and 300 square feet if he sets the spreader to its lowest setting. How many bags of seed will he need if he uses the highest setting? The lowest setting?

Name \_\_\_\_\_

Date \_\_\_\_\_

1. The width of a picnic table is 3 times its length. If the length is  $\frac{5}{6}$ -yd long, what is the area of the picnic table in square feet?

2. A painting company will paint this wall of a building. The owner gives them the following dimensions:

Window A is  $6\frac{1}{4}$  ft  $\times$   $5\frac{3}{4}$  ft.

Window B is  $3\frac{1}{8}$  ft  $\times$  4 ft.

Window C is  $9\frac{1}{2}$  ft<sup>2</sup>.

Door D is 4 ft  $\times$  8 ft.

What is the area of the painted part of the wall?

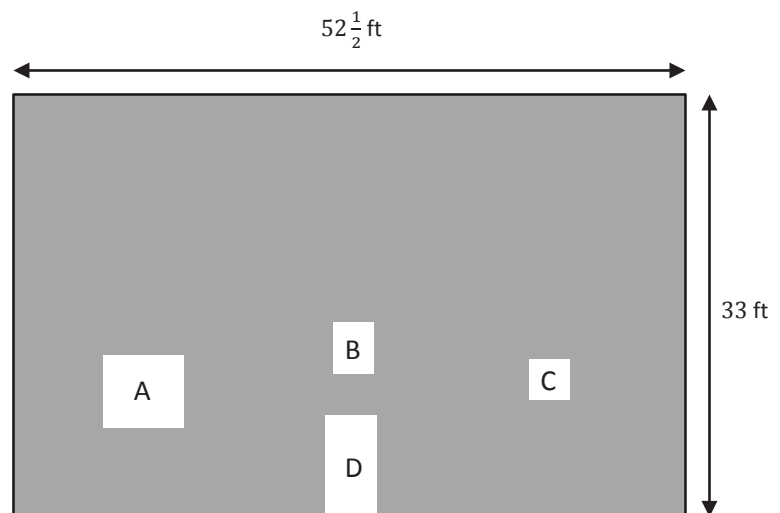

3. A decorative wooden piece is made up of four rectangles as shown to the right. The smallest rectangle measures  $4\frac{1}{2}$  inches by  $7\frac{3}{4}$  inches. If  $2\frac{1}{4}$  inches are added to each dimension as the rectangles get larger, what is the total area of the entire piece?

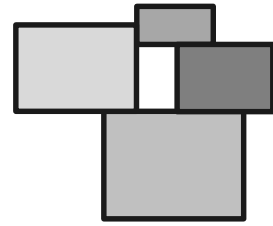

Name \_\_\_\_\_

Date \_\_\_\_\_

1. Use a straightedge and the grid paper to draw:

a. A trapezoid with exactly 2 right angles.

b. A trapezoid with no right angles.

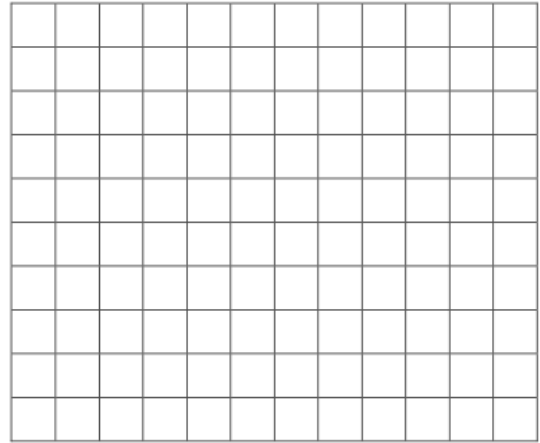
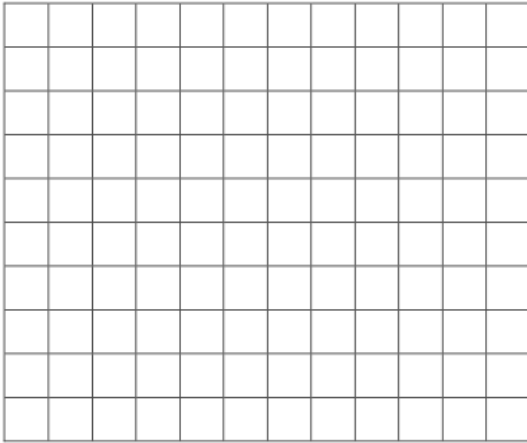

2. Kaplan incorrectly sorted some quadrilaterals into trapezoids and non-trapezoids as pictured below.

a. Circle the shapes that are in the wrong group, and tell why they are sorted incorrectly.

Trapezoids	Non-Trapezoids

b. Explain what tools would be necessary to use to verify the placement of all the trapezoids.

3. a. Use a straightedge to draw an isosceles trapezoid on the grid paper.

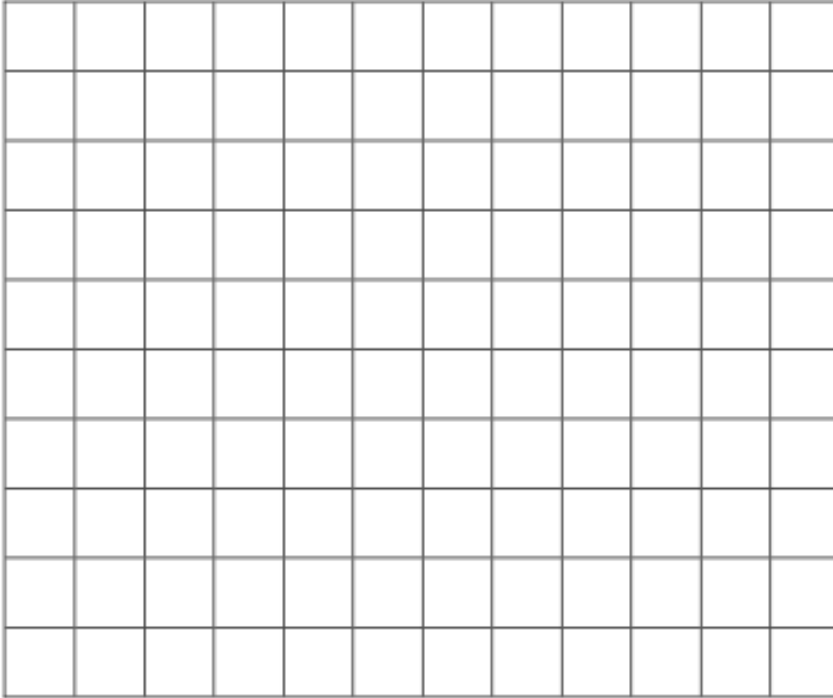

- b. Why is this shape called an isosceles trapezoid?

Name \_\_\_\_\_

Date \_\_\_\_\_

1.  $\angle A$  measures  $60^\circ$ .

- a. Extend the rays of  $\angle A$ , and draw parallelogram  $ABCD$  on the grid paper.
- b. What are the measures of  $\angle B$ ,  $\angle C$ , and  $\angle D$ ?

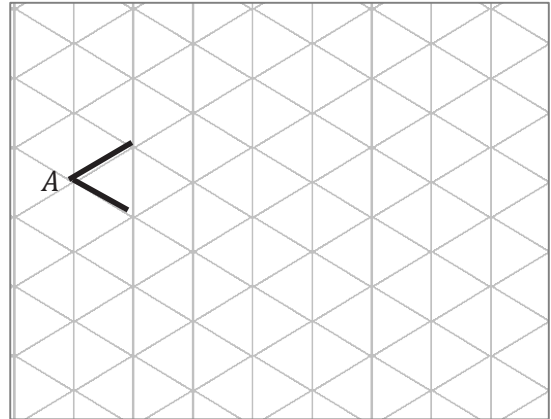

2.  $WXYZ$  is a parallelogram not drawn to scale.

- a. Using what you know about parallelograms, give the measure of sides  $XY$  and  $YZ$ .
- b.  $\angle WXY = 113^\circ$ . Use what you know about angles in a parallelogram to find the measure of the other angles.

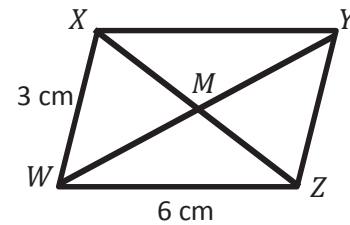

$\angle XYZ = \underline{\hspace{2cm}}^\circ$        $\angle YZW = \underline{\hspace{2cm}}^\circ$        $\angle ZWX = \underline{\hspace{2cm}}^\circ$

3. Jack measured some segments in Problem 2. He found that  $\overline{WY} = 8$  cm and  $\overline{MZ} = 3$  cm.

Give the lengths of the following segments:

$WM = \underline{\hspace{2cm}}$  cm       $MY = \underline{\hspace{2cm}}$  cm  
 $XM = \underline{\hspace{2cm}}$  cm       $XZ = \underline{\hspace{2cm}}$  cm





Name \_\_\_\_\_

Date \_\_\_\_\_

1. Use the grid paper to draw.

a. A rhombus with no right angles

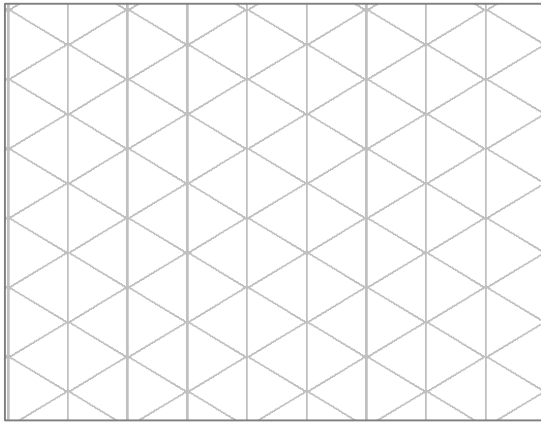

b. A rhombus with 4 right angles

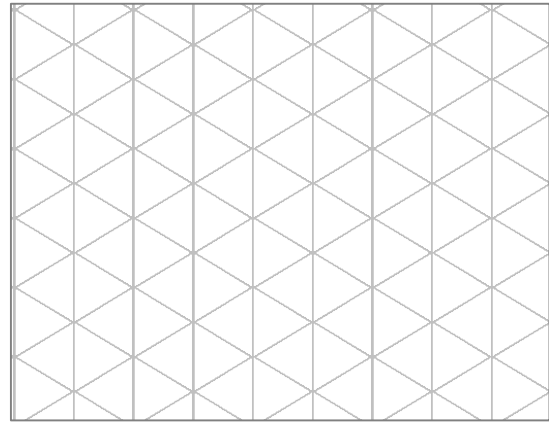

c. A rectangle with not all sides equal

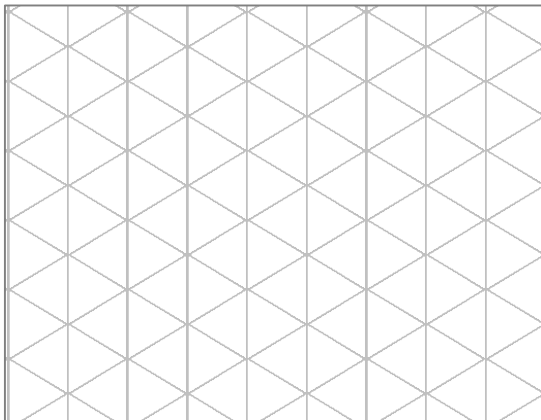

d. A rectangle with all sides equal

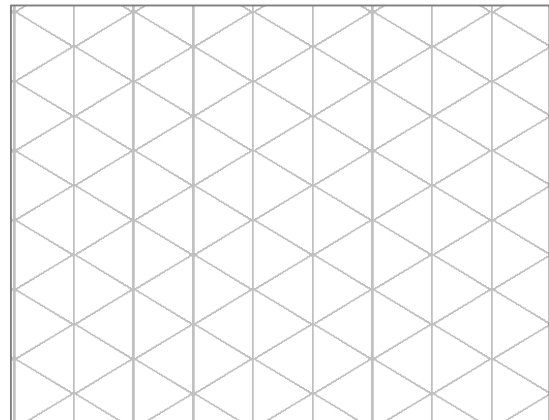



Name \_\_\_\_\_

Date \_\_\_\_\_

1. a. Draw a kite that is not a parallelogram on the grid paper.

b. List all the properties of a kite.

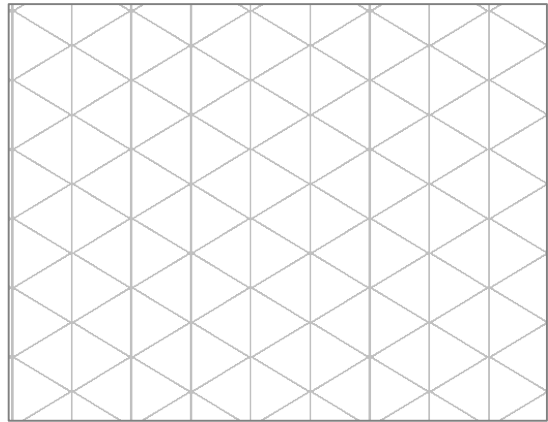

c. When can a parallelogram also be a kite?

2. If rectangles must have right angles, explain how a rhombus could also be called a rectangle.

3. Draw a rhombus that is also a rectangle on the grid paper.

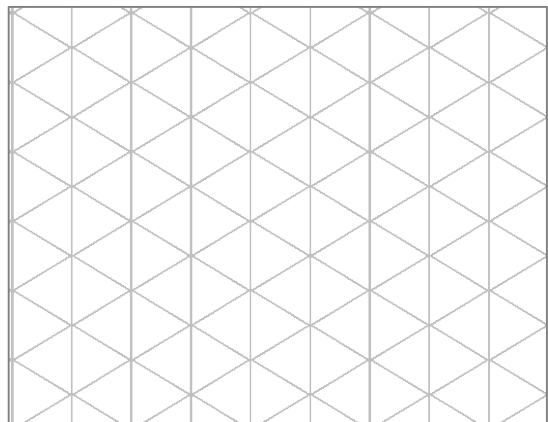

4. Kirkland says that figure  $EFGH$  below is a quadrilateral because it has four points in the same plane and four segments with no three endpoints collinear. Explain his error.

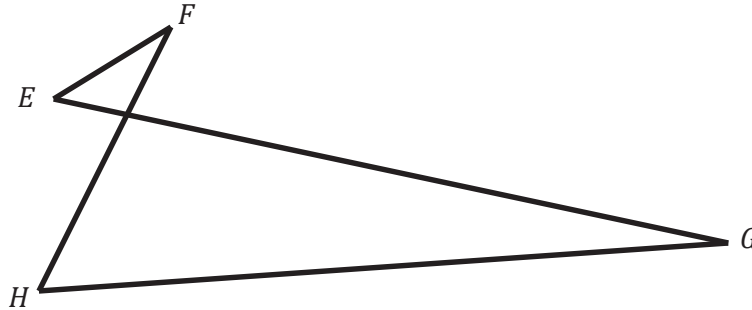

Name \_\_\_\_\_

Date \_\_\_\_\_

1. Follow the flow chart, and put the name of the figure in the boxes.

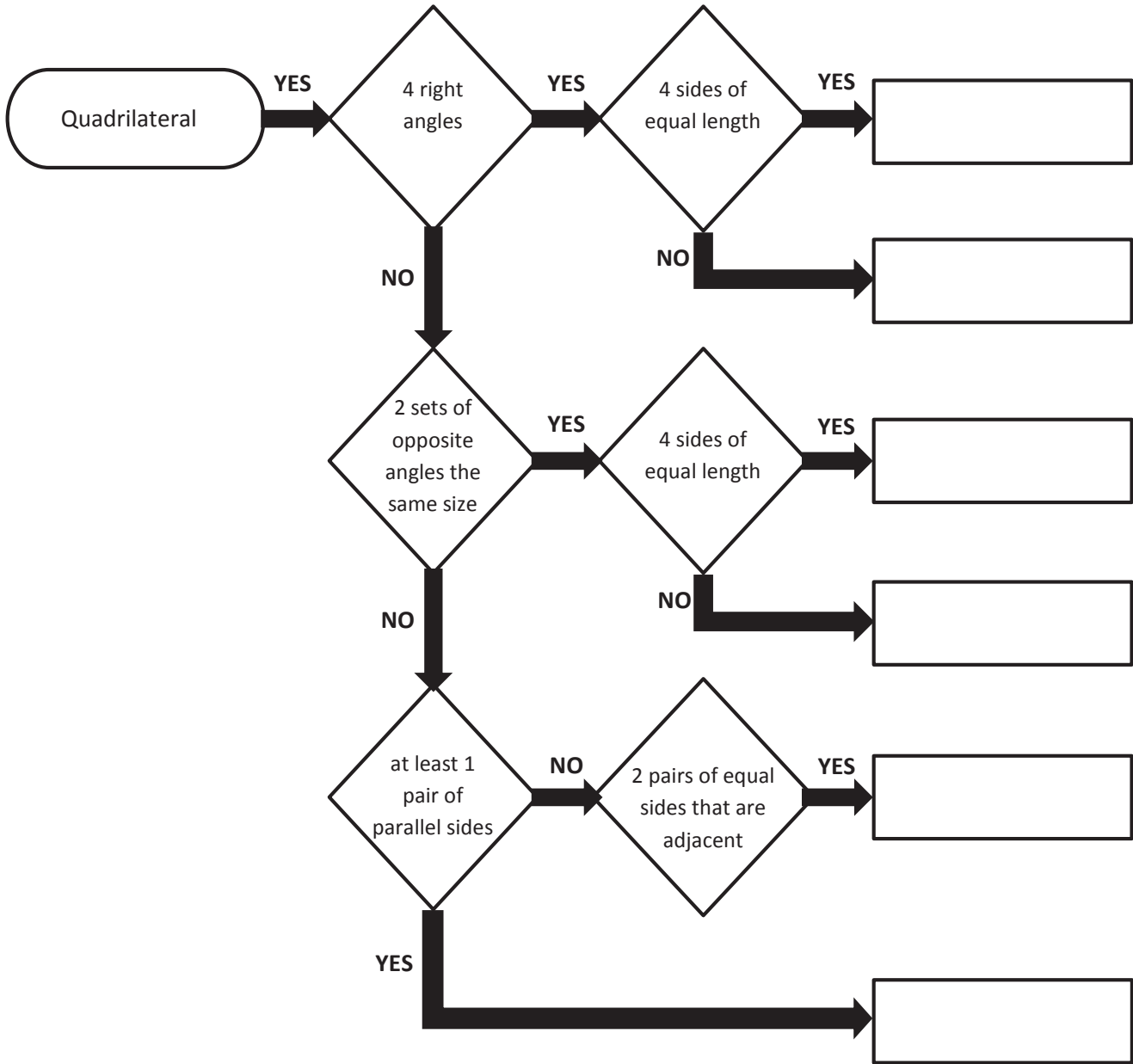

2.  $SQRE$  is a square with an area of  $49 \text{ cm}^2$ , and  $RM = 4.95 \text{ cm}$ . Find the measurements using what you know about the properties of squares.

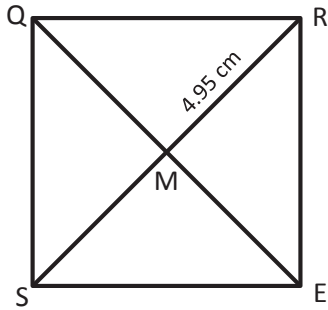

- $RS =$  \_\_\_\_\_ cm
- $QE =$  \_\_\_\_\_ cm
- Perimeter = \_\_\_\_\_ cm
- $m\angle QRE =$  \_\_\_\_\_ $^\circ$
- $m\angle RMQ =$  \_\_\_\_\_ $^\circ$













---

---

Video tutorials: <http://embarc.online>



This work is licensed under a  
Creative Commons Attribution-NonCommercial-ShareAlike 3.0 Unported License.